

KS-70 RACK WASHER



CINCINNATI
INDUSTRIAL MACHINERY

This **ALVEY WASHING EQUIPMENT** machine was installed by

(lead installer)

on the day of

(month / day / year).

Serial #: _____

Customer PO #: _____

Manufacturer SO #: _____

For parts and services, call

ARMOR AFTERMARKET

at

1-800-725-9957

or email partsandservice@armoraftermarket.com



CINCINNATI
INDUSTRIAL MACHINERY
Manufacturer of Alvey® Washing Equipment

KS-70 RACK WASHER

Dear Valued Customer,

Thank you for your trust in, and relationship with CINCINNATI INDUSTRIAL MACHINERY. We hope you have many years of uninterrupted service from our Alvey Brand product.

If you need parts, service, or support, contact **ARMOR AFTERMARKET** at 1-800-725-9957, or email partsandservice@armoraftermarket.com. Some advantages of requesting **ARMOR AFTERMARKET** to fill your replacement parts orders are:

1. Being the original manufacturer of this equipment offers simplicity in order replacement.
2. We are entitled to original equipment manufacturer discounts, which are passed on to our customers.
3. It is our primary responsibility to serve you in a timely and professional manner.

A suggested spare parts list for your machine is included in the CD we are providing your company. This CD has been created to assist you in learning about and using your new machine. The program will help you quickly find documentation and instructions regarding common usage and parts. Adobe Acrobat Reader will be required to view the manual; a download is available from the CD.

If the CD does not start automatically, run "CD_Start.exe" on your CD drive. Should you have problems reading any files, please contact us.

Sincerely,

Cincinnati Industrial Machinery
Documentation and Manual Team and The Parts and Service Department



Section	Title	Page
I.	Warranty and Notice	1
II.	General Description	3
III.	Assembly of Washer and Auxiliary Equipment	6
IV.	Service Connections	8
V.	Start-Up	9
VI.	Sequence of Operations	10
VII.	Shut Down	11
VIII.	Service and Maintenance	12
IX.	Trouble-Shooting Guide	13
X.	Recommended Spare Parts	16
XI.	Illustrations (See Attached)	



All licenses and permits, including without limitation, any building or erection licenses and permits, if necessary, shall likewise be paid by Purchaser; and should Manufacturer be required to furnish any Bond or Bonds on the within contract, the cost thereof shall also be added to the quoted price.

ADDITIONAL MATERIAL AND LABOR - Any material added to, or labor performed on or in connection with the Equipment or installation thereof, shall be at Purchaser's own expense, unless otherwise agreed to in writing by Manufacturer.

SAFETY DEVICES - Manufacturer will supply such safety devices or fire protection equipment as is specified in writing in its proposals. If Purchaser desires or requests through local, State or Insurance Underwriter's Specifications or regulations, other additional safety devices or equipment, Manufacturer will undertake, without being obligated therefore, to furnish same at Purchaser's cost. Manufacturer assumes no liability for loss or damage to persons or property occasioned by any accident or casualty resulting from the use of fuel gas, fuel oil, oven or immersion tube atmosphere gas in connection with the Equipment.

USE OF SPECIFICATIONS AND DRAWINGS - The drawings, designs, specifications and data accompanying any proposal are Manufacturer's property and are subject to recall by Manufacturer at any time. Such drawings, designs, specifications and data, or any part of them, shall not be used by Purchaser for competitive bidding or similar purposes without Manufacturer's prior written approval.

TITLE AND OWNERSHIP - It is the intention that the Equipment be sold to Purchaser and that title to the same shall be acquired by Purchaser upon shipment from Manufacturer's premises. Manufacturer shall retain a purchase money security interest lien on each piece of Equipment, including without limitation, any accessories to such Equipment, proceeds from the sale thereof and any insurance proceeds related to such Equipment, until final payment thereof is made as per the agreed terms. If Manufacturer gives Purchaser possession before final payment is made, it is hereby mutually agreed that:

a) The title and the right of possession of the Equipment shall transfer to the Purchaser upon shipment; provided however, Manufacturer shall retain a purchase money security interest lien on each piece of Equipment, including without limitation, any accessories to such Equipment, proceeds from the sale thereof and any insurance proceeds related to such Equipment until full and final payment therefore (including payment of any promissory notes and/or other security taken in lieu of or in accordance with the terms hereof) shall have been made. Purchaser also authorizes Manufacturer to act as its agent and attorney-in-fact (where permitted by law) for the limited purpose of preparing, executing in Purchaser's name, and filing on its behalf, a financing statement (for example, a UCC-1) to perfect Manufacturer's purchase money security interest in each piece of Equipment. Until title or license has passed to Purchaser and full and final payment has been received by Manufacturer, Purchaser shall not cause nor permit any piece of the Equipment to be sold, leased, or subject to a lien or other encumbrance other than Manufacturer's security interest;

b) In the event of default or breach of any of the Terms and Conditions of the contract, Manufacturer may, at its option, repossess the Equipment and all additions thereto, wherever found, free from all claims whatsoever;

c) Any risk of loss during shipment shall be borne by Purchaser and any loss or damage to the Equipment during shipment shall not relieve Purchaser of its obligations hereunder, including but not limited to making full and final payment to Manufacturer.

The Equipment, or any part thereof, shall not be considered a fixture or be incorporated into realty by reason of its attachment thereto, and may be separated from realty, as well as personality, for the purpose of repossession. Manufacturer shall not be liable to Purchaser, nor shall Manufacturer be subject to any legal proceedings, criminal or civil, for Manufacturer's acts in such repossession, nor for the repayment of any money paid before such repossession as part payment for the Equipment, which shall be retained by Manufacturer as or on account of liquidating damages.



In addition to the purchase money security interest lien described above, Manufacturer shall have the right to elect or assert Manufacturer's claim of a mechanics lien against the property upon which the Equipment may be erected and to waive Manufacturer's right to repossess under section (b) above at any time before the expiration of the time fixed by law for filing such lien.

CLAIMS/LIABILITY -

a) Manufacturer shall not be liable for loss, damage, detention, or delay resulting from causes beyond its control or by acts of God, including floods, and acts of foreign nations, or caused by fire, strike, civil or military authority insurrection or riot, embargoes, car shortages, wrecks or delay in transportation.

b) Manufacturer shall have no responsibility for loss or damage to the Equipment after delivery to the carrier.

c) Manufacturer's liability arising out of the supplying of the Equipment or its use shall not under any circumstances exceed a credit of the purchase price, F.O.B. Manufacturer's factory, of the Equipment.

d) IN NO EVENT SHALL MANUFACTURER BE LIABLE FOR LIQUIDATED DAMAGES, OR INDIRECT, OR CONSEQUENTIAL DAMAGE OF ANY NATURE.

WARRANTIES -

a) Manufacturer warrants to Purchaser that the material and workmanship of the Equipment is of good quality and free of defects and the Equipment of its own manufacture and design delivered hereunder shall be of the kind and quality described in the specifications, and that it shall be suitable for performing the work therein described; provided, however, that the work for which it is intended shall have been fully and adequately presented, shown and described to Manufacturer. The warranty period will start upon shipment from a facility of Manufacturer and conclude based upon a separate prearranged warranty period agreed to in writing by Manufacturer.

b) EXCEPT AS SPECIFICALLY PROVIDED IN (a) ABOVE, MANUFACTURER MAKES NO WARRANTY, EXPRESS OR IMPLIED, RELATING TO THE

EQUIPMENT, ITS MERCHANTABILITY OR FITNESS FOR ANY PARTICULAR PURPOSE.

c) Manufacturer does not provide a separate warranty for parts or components not manufactured by Manufacturer. Equipment, parts and accessories made by other manufacturers are warranted only to the extent of the original manufacturer's warranty to Manufacturer, which if extendable, Manufacturer will extend to Purchaser.

d) In the event of Manufacturer's breach of its warranty as provided in (a) above, Manufacturer's total liability shall be to repair or replace the Equipment and in no event shall Manufacturer have any liability for any consequential, incidental or other special damages, including but not limited to damages or loss of profits resulting from failure of the Equipment or delay caused by its repair.

e) All transportation costs of returning defective goods shall be borne by Purchaser. All transportation costs of returning repaired or replaced products to Purchaser shall be borne by Purchaser.

f) This warranty shall not be in force and effect unless: Purchaser is current with all payments due to Manufacturer; Purchaser gives Manufacturer immediate notice of defective part or parts; Purchaser affords the Manufacturer the opportunity to inspect defective part or parts; material is still property of the original owner; material is still part of the original installation operating under normal usage (eight hours per day and five days per week constitutes normal usage); and material is properly maintained and lubricated per factory instructions.

g) THE ABOVE WARRANTY DOES NOT COVER PARTS WHICH UPON INSPECTION ARE DETERMINED BY MANUFACTURER TO HAVE BEEN SUBJECTED TO MISUSE, NEGLIGENCE, ALTERATIONS, ACCIDENT, ABUSE, DAMAGE BY FIRE, FLOOD OR OTHER SIMILAR CASUALTY.

PATENTS - Manufacturer shall hold Purchaser harmless from any and all costs and damages which shall be recovered against Purchaser in any suit at law or in equity for any infringement of any Letters Patent by reason of the use by Purchaser of the Equipment.



In addition to the purchase money security interest lien described above, Manufacturer shall have the right to elect or assert Manufacturer's claim of a mechanics lien against the property upon which the Equipment may be erected and to waive Manufacturer's right to repossess under section (b) above at any time before the expiration of the time fixed by law for filing such lien.

CLAIMS/LIABILITY -

a) Manufacturer shall not be liable for loss, damage, detention, or delay resulting from causes beyond its control or by acts of God, including floods, and acts of foreign nations, or caused by fire, strike, civil or military authority insurrection or riot, embargoes, car shortages, wrecks or delay in transportation.

b) Manufacturer shall have no responsibility for loss or damage to the Equipment after delivery to the carrier.

c) Manufacturer's liability arising out of the supplying of the Equipment or its use shall not under any circumstances exceed a credit of the purchase price, F.O.B. Manufacturer's factory, of the Equipment.

d) IN NO EVENT SHALL MANUFACTURER BE LIABLE FOR LIQUIDATED DAMAGES, OR INDIRECT, OR CONSEQUENTIAL DAMAGE OF ANY NATURE.

WARRANTIES -

a) Manufacturer warrants to Purchaser that the material and workmanship of the Equipment is of good quality and free of defects and the Equipment of its own manufacture and design delivered hereunder shall be of the kind and quality described in the specifications, and that it shall be suitable for performing the work therein described; provided, however, that the work for which it is intended shall have been fully and adequately presented, shown and described to Manufacturer. The warranty period will start upon shipment from a facility of Manufacturer and conclude based upon a separate prearranged warranty period agreed to in writing by Manufacturer.

b) EXCEPT AS SPECIFICALLY PROVIDED IN (a) ABOVE, MANUFACTURER MAKES NO WARRANTY, EXPRESS OR IMPLIED, RELATING TO THE

EQUIPMENT, ITS MERCHANTABILITY OR FITNESS FOR ANY PARTICULAR PURPOSE.

c) Manufacturer does not provide a separate warranty for parts or components not manufactured by Manufacturer. Equipment, parts and accessories made by other manufacturers are warranted only to the extent of the original manufacturer's warranty to Manufacturer, which if extendable, Manufacturer will extend to Purchaser.

d) In the event of Manufacturer's breach of its warranty as provided in (a) above, Manufacturer's total liability shall be to repair or replace the Equipment and in no event shall Manufacturer have any liability for any consequential, incidental or other special damages, including but not limited to damages or loss of profits resulting from failure of the Equipment or delay caused by its repair.

e) All transportation costs of returning defective goods shall be borne by Purchaser. All transportation costs of returning repaired or replaced products to Purchaser shall be borne by Purchaser.

f) This warranty shall not be in force and effect unless: Purchaser is current with all payments due to Manufacturer; Purchaser gives Manufacturer immediate notice of defective part or parts; Purchaser affords the Manufacturer the opportunity to inspect defective part or parts; material is still property of the original owner; material is still part of the original installation operating under normal usage (eight hours per day and five days per week constitutes normal usage); and material is properly maintained and lubricated per factory instructions.

g) THE ABOVE WARRANTY DOES NOT COVER PARTS WHICH UPON INSPECTION ARE DETERMINED BY MANUFACTURER TO HAVE BEEN SUBJECTED TO MISUSE, NEGLIGENCE, ALTERATIONS, ACCIDENT, ABUSE, DAMAGE BY FIRE, FLOOD OR OTHER SIMILAR CASUALTY.

PATENTS - Manufacturer shall hold Purchaser harmless from any and all costs and damages which shall be recovered against Purchaser in any suit at law or in equity for any infringement of any Letters Patent by reason of the use by Purchaser of the Equipment.



herein specified; provided and upon the express condition that the Equipment is used in the manner directed and exclusively for the purpose for which it is sold without any changes and installed or used in compliance with Manufacturer's plans and instructions, and upon further express condition that Purchaser shall immediately after service of the writ in any such suit at law or in equity notify Manufacturer in writing of the commencement of such suit, giving the names of the parties and the title of the court, and shall permit Manufacturer to defend same by its own counsel and at its own expense and to have exclusive control and management of the defense, and that Purchaser shall give Manufacturer all needed information, assistance and authority to enable Manufacturer to defend such suit.

INDEMNIFICATION - Purchaser agrees to indemnify Manufacturer, and hold Manufacturer harmless from, all costs and expenses incurred by Manufacturer, including, without limitation, costs of investigation, attorneys' fees, and amounts paid in settlement or satisfaction of claims, proceedings, or judgments, in connection with all claims and proceedings against Manufacturer based upon claimed defects in design in any item or items manufactured for Purchaser by Manufacturer to Purchaser's design and/or specifications.

CANCELLATIONS - In the event Purchaser should request cancellation of this contract, or part of it, Purchaser agrees to pay Manufacturer the contract price on any articles which are delivered and ready for delivery on the date when such cancellation becomes effective. As to all such articles not so delivered, Purchaser shall have the option:

- 1) To require completion and to pay the contract price thereof; or
- 2) To reimburse Manufacturer for actual expenditures made with respect to the articles which are uncompleted; to reimburse Manufacturer for commitments incurred with respect to the uncompleted articles of the contract; and to pay Manufacturer for the anticipated profit of the entire contract.

Manufacturer may, by written notice to Purchaser and without any liability, cancel Purchaser's contract if

Purchaser (i) fails to perform any of the terms and conditions hereof and does not cure such failure within a period of 10 days after receipt of written notice from Manufacturer specifying such failure: (ii) in Manufacturer's opinion has not established or maintained credit to meet promptly the payment terms imposed by Manufacturer: (iii) becomes insolvent, makes an assignment in favor of creditors, or becomes subject to any bankruptcy, dissolution, or similar proceedings; or (iv) is merged into, or all or a substantial part of its assets are sold to, another company.

FORCE MAJEURE - Delays by Manufacturer or by Purchaser in the performance of this contract shall be excused whenever Manufacturer or the supplying manufacturer is prevented from producing or delivering, or Purchaser from receiving or using the above material, by strikes, differences with workmen, fires, accidents, delays or difficulties in transportation acts of God or the public enemy, or other causes beyond the reasonable control of Purchaser or of Manufacturer or of the supplying manufacturer, as well as acts or demands of the government in times of war or national emergency. Any such delayed performance, however, shall not in any way invalidate this contract or any part thereof.

JURISDICTION - Purchaser irrevocably consents and voluntarily submits to personal jurisdiction of the courts located in Warren County and the United States District Court for the Southern District of Ohio, Western Division in any proceeding arising out of or relating to the contract and agrees that all claims raised in such proceeding may be heard and determined in such court.

GOVERNING LAW - The contract shall be governed by and construed in accordance with the internal laws of the State of Ohio, United States of America, without regard for its choice and or conflict of laws provisions and without regard to the United Nations Convention on Contracts for the International Sale of Goods.

Purchase Orders and/or contracts may only be accepted in writing by an authorized representative of Manufacturer from the Mason Office of Armor Metal Group.

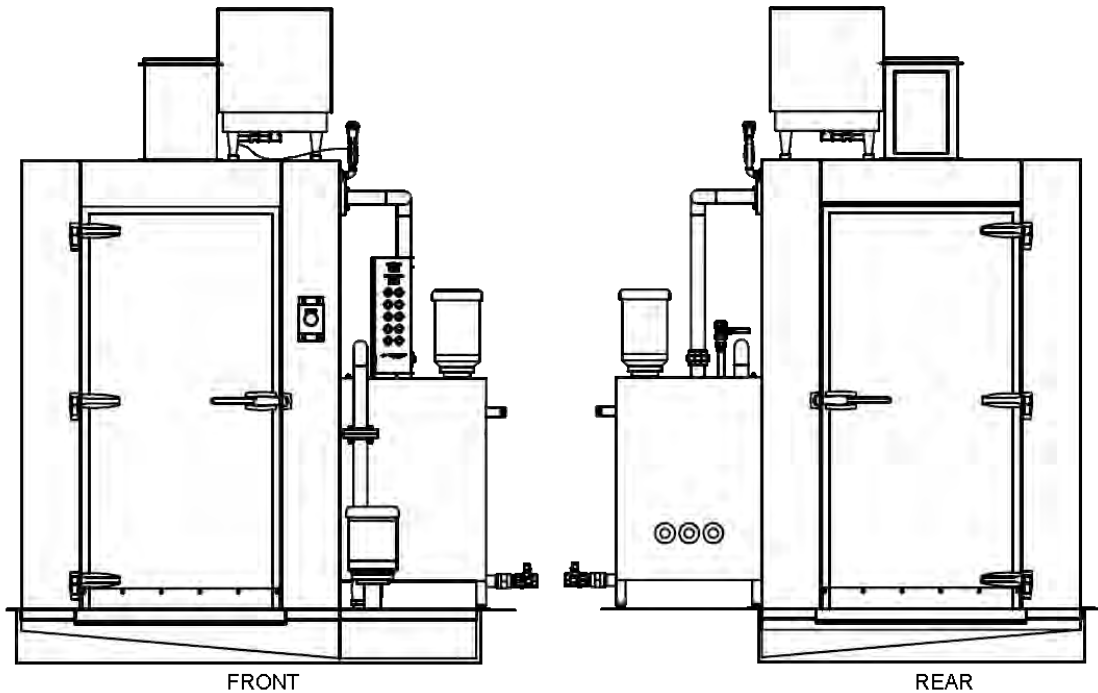

Pit-Mounted Option Shown

OVERVIEW

The model KS-70 is a walk-in type compact stainless steel cabinet washer designed to clean racks, carts, and delivery cabinets. The washer is fully assembled and tested at the factory, then knocked down and crated for shipment and re-assembly at the job site. The machine is designed for installation in a shallow pit. When constructing a pit is not desired, a floor-mounted option with load ramp or a side-mounted tank can be ordered.

The machine subjects work to a recirculating high-pressure spray wash through two rotating spray arms followed by a fresh water rinse. The wash tank is manually filled with cold or hot water which is heated by one of the optional systems: a steam injector, steam heated coils, electric immersion heaters, or a natural gas or propane burner. The wash water temperature is thermostatically controlled.

AVAILABLE OPTIONS

- Rinse water booster heater - electric, gas or steam
- Exhaust fan with controls - factory wired
- Draft inducer for gas burner exhaust - factory wired
- Higher capacity pump
- Second door for pass through operation
- Double capacity with two additional wash arms
- Insulated housing
- Automatic water fill
- Carts, racks, and baskets
- Floor-mounted tank and load ramp
- Side-mounted tank



Selecting a Location

When selecting the location to install your Alvey KS-70 Rack washer, review the dimension sheets and consider access to the utility requirements. Determine the minimum distance from outside wall or roof to optimize ventilation. Ensure there is ample floor space for maintenance and for storage of cleaned and soiled work. Finally, confirm whether the machine is pit or floor mounted. If pit mounted, ensure that the pit for the tank has been constructed. If floor mounted, confirm that there is sufficient space for the machine loading ramp.

Receiving the Machine

The machine will be received disassembled. The wash chamber and attached equipment have been removed from the tank in preparation for shipment. Panel flanges and tank is match marked before disassembly of wash chamber. Wiring is disconnected at junction boxes with leads marked; piping is disconnected at unions. Solenoid coils are slipped off valves and remain attached to conduit assemblies. Mounting hardware is left attached to studs on cabinet panels. An assembly kit contains an adequate length of sealing strip, tubes of silicone caulk, and sufficient hardware to secure chamber panels.

Examine equipment for agreement with packing slip and dimension sheet. Notify factory immediately concerning any shortages or shipping damage.



Preparation for Assembly

Inspect pit to assure agreement with drawing and dimension print. Examine panels; determine assembled location of each panel by noting match marks and equipment mounting stud locations. Note that flange shape determines order of assembly of panels. Clean flange faces of tank and chamber panels after removing protective paper.

Tank Assembly

Locate tank assembly in desired positions and levels. If unit is suspended on edge of pit by a boundary angle, leveling is not required.

Sealing Strip

Place sealing strip on tank and chamber panel flanges. One strip is required per joint. Avoid door area. Strip is tacky and will remain in place. Applying a liquid soap solution to exposed surface of strip will allow panels to be more easily shifted during bolting. Use silicon caulk at corners where sealing strips join and other areas where leaks might occur.

Chamber Panels

Install chamber panels.

1. After removing door, locate front panel assembly in position on tank.
2. Locate right and left rear corner panels in position on tank. (If washer has pass through option, repeat steps 1 for second door.)
3. Temporarily position rinse manifolds in chamber, before continuing, as they will not easily fit through door.
4. Continue setting the remaining vertical panels in position and loosely bolt.
5. Now place front and rear top panels in position before installing center top panel. Be certain to apply caulk at corners as before. Loosely bolt.
6. Reinstall door into front panel assembly. Align assembly so that door will latch and seal properly; tighten only those bolts holding front assembly to the tank.
7. Align next adjacent panels and tighten bolts attaching them to the front panel assembly. Start at the bottom. Repeat for each successive

vertical panel until all are secure. If washer has second door, repeat step 6 for rear panel assembly.

8. Now tighten the remaining bolts holding the vertical panels to tank and to top.
9. Tighten bolts securing top panels to each other.

Interior Piping

1. Attach interior rinse piping to rinse manifolds at unions and extend threaded nipple through chamber wall. Secure with pipe nuts and rubber and metal washers. Bolt rinse manifold brackets to chamber panel flanges.
2. Screw vertical wash pipes tightly into wash manifold and then bolt spray elbows to wash pipes and chamber flanges.
3. Install wash arms assemblies and align with chamber wall to avoid interference with rinse manifolds and guard rails. Be sure all pipe joints are tight.
4. Install guard rails and verify that they do not interfere with wash arms.

Control Panel

Install control panel and conduit assemblies and attach related wiring.

1. Attach control panel and conduit assemblies to housing with studs and nuts provided. Connect wires at appropriate locations on terminal strip. See wiring diagram.
2. Attach proximity switch 1PROX to bracket by door and associated magnet and bracket to studs provided on door. With pass through option, repeat with second door.
3. Connect flexible conduit to motor (leads IT1, IT2, IT3) and to gas burner (leads 14, 16, 17, 2) (Gas heated tank only.)
4. Attach flexible conduit from float switches to fittings on conduit assembly; connect tagged wires (3, 12). Only washers with electric and gas tank heat have a low-level float. Only washers with automatic water fill have a high level float.
5. Assemble STEAM HEAT solenoid coil (2, 15) onto steam solenoid valve. (Steam heated tank only.)



Gauge Panels

Install gauge panel and related temperature and pressure probes.

1. Attach panel to chamber on studs provided.
2. Install probe from wash temperature gauge into bracket provided in tank.
3. Install probe from rinse temperature gauge into fitting on external rinse manifold.
4. Install fitting on wash pressure gauge tubing into tapped hole on wash pump.
5. Install capillary tube from temperature control into bracket next to wash temperature probe.

Exterior Piping

Install exterior rinse piping assembly (and booster heater when provided).

1. Place booster heater, when provided, in required position.
2. Attach external rinse piping assembly to nipple extending through chamber wall. Attach rinse solenoid coil to valve on piping assembly with clips provided.
3. Steam booster heater option - Attach water inlet, steam inlet and condensate piping assemblies to booster heater. Attach rinse booster solenoid coil to steam valve. Attach piping assembly between booster and external rinse manifold.
4. Electric and gas booster heater option - Attach piping assembly between booster and external rinse manifold.
5. Verify that all rinse water and steam connections are tight.

Exhaust Fan

Install exhaust fan and draft inducer. Position fan assembly and attach with gasket and hardware provided. Draft inducer must be installed in exhaust stack above draft hood by customer. Connect the flexible conduit provided to each motor and attach leads.

Caulk

Caulk cabinet and trim sealing strip. Caulk around base of machine between tank and floor and between tank and cabinet. After initial start up, caulk as required, to eliminate leaks. The sealing strip used at housing seams will tend to extrude out during the first few weeks of service. This can be trimmed back with a utility knife.



Service Connections

TANK WATER FILL

Connect cold water line to 1" ball valve on side of washer.

FRESH WATER RINSE

Connect 3/4" hot water line to strainer on rinse water manifold. The rinse flow rate is controlled by the quantity and size of rinse nozzles. See dimension sheet for rated flow. Recommended rinse temperature: 180 – 195° F.

When optional booster heater is provided, connect hot water line directly to booster. Consult dimension prints for size and location of connection. Both the electric and gas boosters come complete with pressure regulators.



Note: To maintain a consistent rise flow rate, install pressure regulator and adjust for 20 PSI.

DRAIN

Provide pit with a 2" minimum drain located to allow access when washer is in position. Tank drain and overflow empty into pit.

With floor mounted machine, a common 2" outlet for tank and overflow is provided for direct connection to customers drain line. Use union or flanged connection to allow washer to be easily disconnected.

STEAM SERVICE—STEAM HEATED TANK

Connect service to steam inlet valve. Minimum operating pressure is 10 PSI. When steam plate coil heat is supplied, a 3/4" condensate return line is required.



Note: If there is backpressure in the condensate return line, install a check valve after steam trap for satisfactory performance of the steam coil.

STEAM SERVICE—BOOSTER HEATER

Connect 1 1/2" line with 10-15 PSI pressure to the valve on booster inlet. A 3/4" condensate return line is required; see Sec. V D note.



Note: High booster steam pressure will cause an excessive amount of rinse water to flash into steam. Install a steam pressure regulator to control the rinse temperature.

GAS SERVICE

Connect 3/4" gas line with manual shut off valve and drip leg to burner inlet of gas heated washers. Make a similar connection to gas booster heater when provided. Consult dimension prints for line size.

FIRE TUBE EXHAUST—GAS HEATED TANK

Connect 8" dia. stack and draft hood to 6 5/8" outside diameter burner exhaust tube. The stack should have no horizontal run; stack sections should be lapped in the direction of flow. It may be advisable to install damper in exhaust stack to control draft. See sketch.



Note: A draft inducer will be required under any of the following conditions:

- Building is under negative pressure
- Outside air currents produce down drafts
- Exhaust stack design causes excessive restriction
- Required by local codes



Note: Stack temperature can exceed 600° F. Selection of proper material is the customer's responsibility.

Use 7 9/16" inside diameter watertight duct with inside lapping of joints in direction of flow. Use gasket between fan and washer housing to prevent condensate from seeping. See sketch.

ELECTRICAL—WASHER

Connect outside power line to L-1, L-2 and L-3 on the terminal block in the control panel. A fused disconnect shall be provided within sight of the washer to prevent danger of shock. See dimension sheet for power requirements.

ELECTRICAL—GAS AND ELECTRICAL BOOSTER HEATERS

A separate power line with a fused safety switch must be provided for gas and electric booster heaters. See dimension sheet for power requirements. See booster heater installation and operating manual enclosed.



Note: Do not obstruct loading area with service connections.

Local sales or factory representative will assist in initial start up unless otherwise stated in order.

Tank Preparation

1. Remove grip strut walkway from inside of machine. Open drain valve. Remove filter and pump protection screens.
2. Flush out tank and inside walls, preferably with high-pressure hose, to remove contaminants, which may remain from fabrication, shipment, or installation. With subsequent cleaning, after washer operation, care must be taken to clean float switches, heating elements, tank corners, and pump compartment.
3. When cleaning is completed, close drain and replace screens and walkway.
4. To fill tank open manual valve and allow water to rise to the overflow level. If option included on washer, press AUTOMATIC WATER FILL button on the control panel.



Note: During first week of operation, closely inspect spray nozzles and hub assemblies for debris which may have collected. Clean as per IX.B.

Rotation of Motors

On initial start-up, check rotation of all motors.

Activating Tank Heat Assembly

1. Verify that tank is filled. Low level cutoff float, provided with gas and electric heat, will prevent tank heat from being activated when water is low.
2. Set desired wash temperature (140°-160° F).
3. Turn on power to washer at disconnect switch.
4. Steam Heat - Open manual steam valve; turn control panel heat switch to ON.
5. Electric Heat-Turn control panel HEAT switch to on.



Note: Gas burner delay timer (1TR) in control panel prevents buildup of fumes in burner prior to ignition. Timer is preset at five seconds.

6. Gas Heat
 - a. Open manual gas valve and turn combination gas valve to ON.
 - b. Turn control panel heat switch to ON.
 - c. Burner is automatically lit. The draft inducer, when furnished, will be energized.
 - d. A damper in exhaust stack should be used to control the amount of draft.



Note: We recommend adjustments to the burner be made by your local gas company or a reputable service company.



Caution: Shut off power at the disconnect before opening the control panel.

Rinse Water Temperature Control

When hot water is supplied directly to the washer rinse manifold, customer's heater must be adjusted to provide the desired temperature on the rinse temperature gauge in the control panel.

The electric and gas booster heaters are thermostatically controlled and preset at time of manufacture to provide a (180-195 deg. F) rinse. Consult the respective operating manual enclosed.

The steam booster heater is sized to provide a (180-195 deg. F) rinse at rated flow and pressure when supplied with 10-15 PSI. of steam. See dimension print. Further temperature adjustment can be made by use of a steam pressure regulator.

Detergent

When the wash water reaches operating temperature, add desired amount of cleaning compound. Consult chemical supplier for recommendations.

(Cont.)



Important: For satisfactory cleaning the proper detergent must be used.



Detergent (Cont.)

Use of an automatic detergent dispenser is recommended. To insure economical use of the compounds, sensing probes must be kept clean of any foreign matter. If in powder form, pour detergent into wash tank, close door, and run wash cycle until compound has been dissolved. Avoid rinse cycle to prevent unnecessary dilution. Consult chemical supplier for equipment recommendations.



Important: Cleaning compound should be the non-foaming type, and not contain substances that will react with copper or aluminum.



Note: See note on electrical diagram for soap dispenser hookup

Daily Start-Up

1. Turn on power at customer-provided Disconnect Switch. Electric or gas booster will be connected to a disconnect separate from washer
2. Turn on washer's Main Power Switch. The white "Power On" indicator will light.
3. Ensure that the drain valve is in the closed position.
4. Close door to begin automatically filling the tank. The unit will stop filling the tank when the proper level is reached.
5. Turn on the Wash Heat Switch to activate the steam heat coil in the wash tank.

Sequence of Operation

1. Set the wash temperature controller, located on the front of the main control panel, to 160°F / 71.1°C (See temperature controller manual for setting instructions).
2. When the temperature for the wash tank reaches the 160°F/71.1°C set point, the washer door can be opened and the racks can be loaded.
3. Adjust the Cycle Time Switch to the light, medium or heavy soil position depending soil conditions.
4. Push the green Cycle Start Button to begin wash cycle. The red In Cycle Indicator will light, and stay lit until the cycle is complete.
5. Unload washer after In Cycle indicator goes off and wash cycle ends.

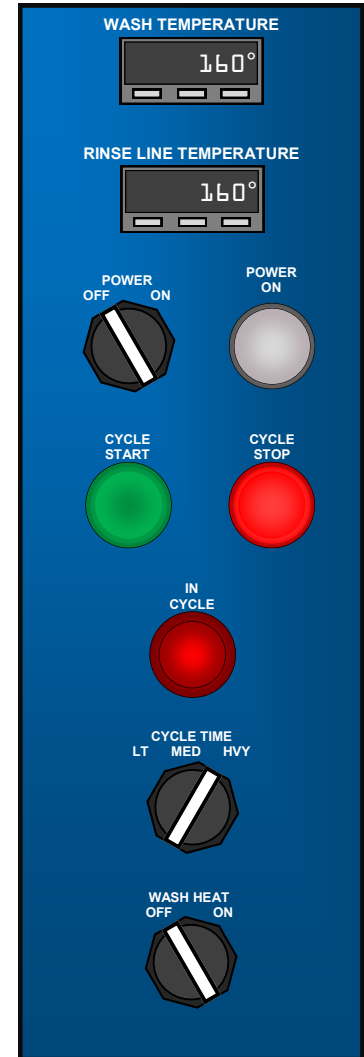

 **Note:** When washer is connected to central exhaust system, means must be provided to prevent the exhaust of moist air during the operation of the washer.

Detergent

When the solution reaches operating temperature, add the proper amount of cleaning compound at the rate recommended by your chemical supplier. If the detergent is in a powder form, pour the powder in the filter baskets, then close the door and run the pump until all compounds have been dissolved. If the compound has been broken up or partially dissolved, this operation will go faster.

 **Notes:** Use of an automatic detergent dispenser is recommended. To insure economical use of the compounds, be sure that the sensing probes are kept clean of any foreign matter. Consult your cleaning compound supplier for recommendations. To obtain satisfactory cleaning, we cannot stress enough the importance of the proper detergent. The temperature controller is located in the control panel.

 **Caution:** The cleaning compound should be the non-foaming type and should not contain a chemical substance that will damage copper or aluminum.



Shut-Down

1. Turn heat switch to off.
2. Drain machine completely.
3. Remove the filter and pump protection screens; flush tank and inside walls with water. Clean sludge and scale from the heating system and float switches.
4. Prepare for next start up. Fill wash tank and add detergent. Run wash pump through 2-minute cycle to flush out piping and moving parts. The door should be left partially open to help eliminate odors.
5. Turn off power at disconnect switch.



Service & Maintenance

PUMP

Your Alvey Pan Washer is equipped with a vertical immersion pump without seals. Pump discharge pressure is 35 to 45 PSI. To help prevent pump damage periodically check pump casing for any foreign matter. Grease pump motor every six months. Check direction of rotation after electrical maintenance.

NOZZLE CLEANING AND ADJUSTMENT

1. Poke debris clogging the nozzles back into the spray arm.
2. Remove nozzle at end of spray arm.
3. Close door and run pump for 5 seconds. Debris will be flushed out.
4. Replace nozzle.



Note: When nozzles are removed, care must be taken to adjust them to their original position when replacing. See Figure 1.

CLEANING OF HUB ASSEMBLIES

Remove spray arm assembly and flush out bearing with clean water. Rotate by hand until hub moves freely.

OPTIONAL EXHAUST FAN

The exhaust fan removes steam vapors from cabinet when door is open. Two types of fans can be furnished, a squirrel cage and a tube axial type. The

squirrel cage fan is equipped with sealed bearings, which will not need grease. The tube axial fan bearings should be greased at regular intervals. See fan operating and maintenance instructions included with this manual.

OPTIONAL RINSE WATER BOOSTER HEATERS

The booster heater raises the water temperature to meet sanitation requirements for rinsing (180° - 195° F). See Sec. V for required services. Each booster has been designed and selected to operate on specific pressures, temperatures and volumes. Operating conditions must be known at time of order to assure a booster is selected that will give satisfactory performance.

PERIODIC SERVICE AND MAINTENANCE

1. Check filter screens twice daily. More frequently with heavy cleaning load.
2. Check wash nozzles for clogging twice daily. This can done at noon break and after shut down.
3. Check twice daily to see that spray hubs turn freely.
4. Drain solution from the tank and flush at least once daily. (See Sec. IV A).
5. Keep washer exterior free from an accumulation of items, which may block air circulation to pump. The exterior appearance may be maintained by wiping with a damp cloth. Stainless steel wax or polish may be applied if desired.

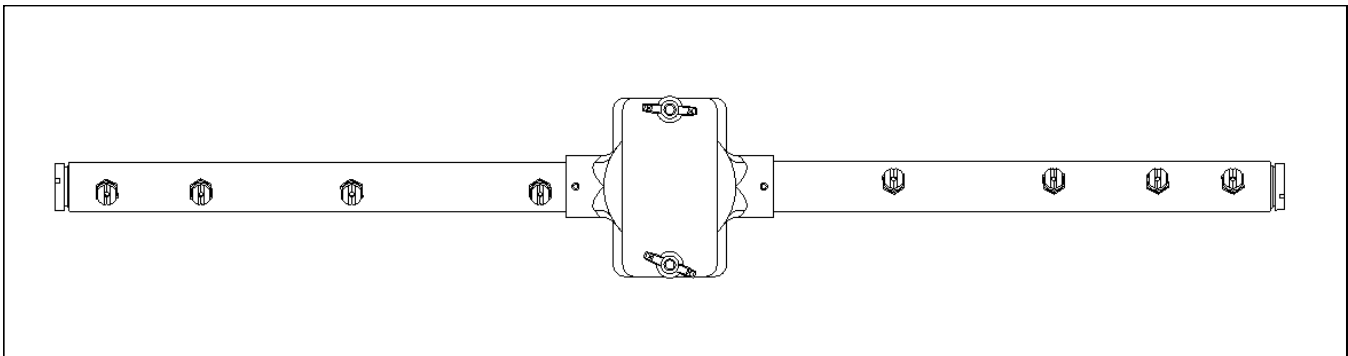

Figure 1: Positioning of Nozzles on Spray Arm



Wash Pump

PROBLEM	DIAGNOSIS
Low Pressure	Pump is running backwards.
	Nozzles missing.
	Leak in discharge piping.
	Faulty pressure gauge.
	Excessive soap suds.
	Pump suction clogged.
High Pressure	Clogged nozzles or discharge piping.
	Faulty pressure gauge.
Pump Vibration	Worn impeller.
	Worn wear ring.
	Bent shaft.
	Clogged impeller.

Wash Pump

PROBLEM	DIAGNOSIS
Motor overheating.	Low voltage.
	High current draw - missing spray nozzles.
	Faulty motor or motor cooling fan.
	Motor running backwards.
Motor vibration.	Bent shaft.
	Worn bearings.
Motor will not start.	Blown fuse on transformer secondary.
	Overload has dropped out.
	Faulty door switch—door not fully closed.
	Faulty programmable relay.

Spinning Arm Assembly

PROBLEM	DIAGNOSIS
Arms will not turn.	Foreign materials in hub assembly.
	Interference with guard rails.
Excessive play in arm.	Worn bushing in hub assembly.



Rinse

PROBLEM	DIAGNOSIS
Will not shut off.	Faulty programmable relay.
	Dirty rinse valve (piston sticking open).
Will not turn on.	Faulty programmable relay.
	Dirty rinse valve (piston sticking closed).
	Faulty valve coil.
Excessive water vapor.	Water temperature too high.
Rinse temperature too low.	Water pressure/flow too high.
	Inlet water temperature too low—does not match design conditions.
	Gas/Electric booster—temperature controller improperly adjusted.
	Steam Booster—low steam pressure.
	Steam Booster—clogged strainer.
	Steam Booster—back pressure in condensate line.
Steam Booster—faulty steam trap.	

Exhaust Fan / Motor

PROBLEM	DIAGNOSIS
Fan/motor vibration.	Worn bearings.
	Wheel out of balance.
	Bent shaft.
Motor overheating.	Low voltage.
	Bent shaft.
	Worn bearing.
	Running backwards.



Steam Injector and Plate Coil

PROBLEM	DIAGNOSIS
Will not heat.	Low steam pressure.
	Clogged injector.
	Clogged strainer.
	Back pressure in condensate line. (Plate coil only.)
	Faulty steam trap.
Overheats.	Temperature controller improperly adjusted.
	Faulty temperature controller.

Gas Burner

PROBLEM	DIAGNOSIS
Will not light.	Gas turned off.
	Faulty temperature controller.
	Faulty thermocouple.
	Faulty igniter, igniter module, or plug. (See Burner manual for more.)
	Faulty low level float switch.
Shuts off periodically.	Loss of gas (Low/High Pressure).
	Improper adjustment of complete unit.
	Negative air pressure.
Fire will not enter tube.	Negative air pressure—draft inducer required.
Overheats.	Temperature controller set too high.
	Faulty temperature controller.
Does not heat.	Low gas pressure.
	Temperature set too low.
	Mixture too lean.
	Mixture too rich.
	Faulty temperature controller.

Control Panel

A qualified electrician should be called in for trouble-shooting and repair of the washer controls.



CINCINNATI
INDUSTRIAL MACHINERY



AMTIVO

ISO 9001:2015
Certified

Quality Management